

Vibratory Screen Cleaners

type RKS

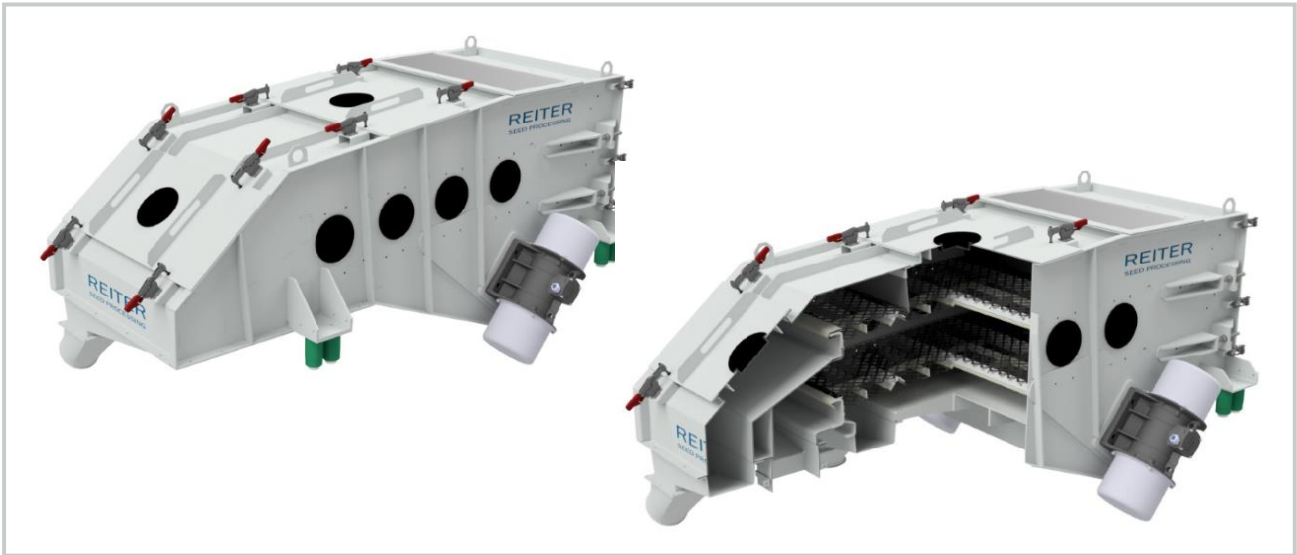

- Suitable for separation of cereals or other bulk goods from foreign or fine materials
- Easy to clean and maintain
- Solid steel construction

Standard Design

- Dust-proof, closed design
- Driven by two vibrators
- Inlet with flexible connection
- Outlets with flexible connections for prime product and waste
- One screen layer with 0,5 m² (RKS 500x1000) / 2,0 m² (RKS 1000x2000) screen area
- Screen with wire mesh (mesh size according to requirements)
- Aspiration spout
- Two removeable inspection covers

Options

- Frequency converter for continuous adjustable motor rpm
- Execution in stainless steel (suitable for food)
- Flexible connections and sealings in food approved quality
- Quick fastener for inspection covers
- Quick fastener for easy and fast screen exchange
- Execution with two screen layers for coarse - medium - fine separation

Vibratory Screen Cleaners

type RKS

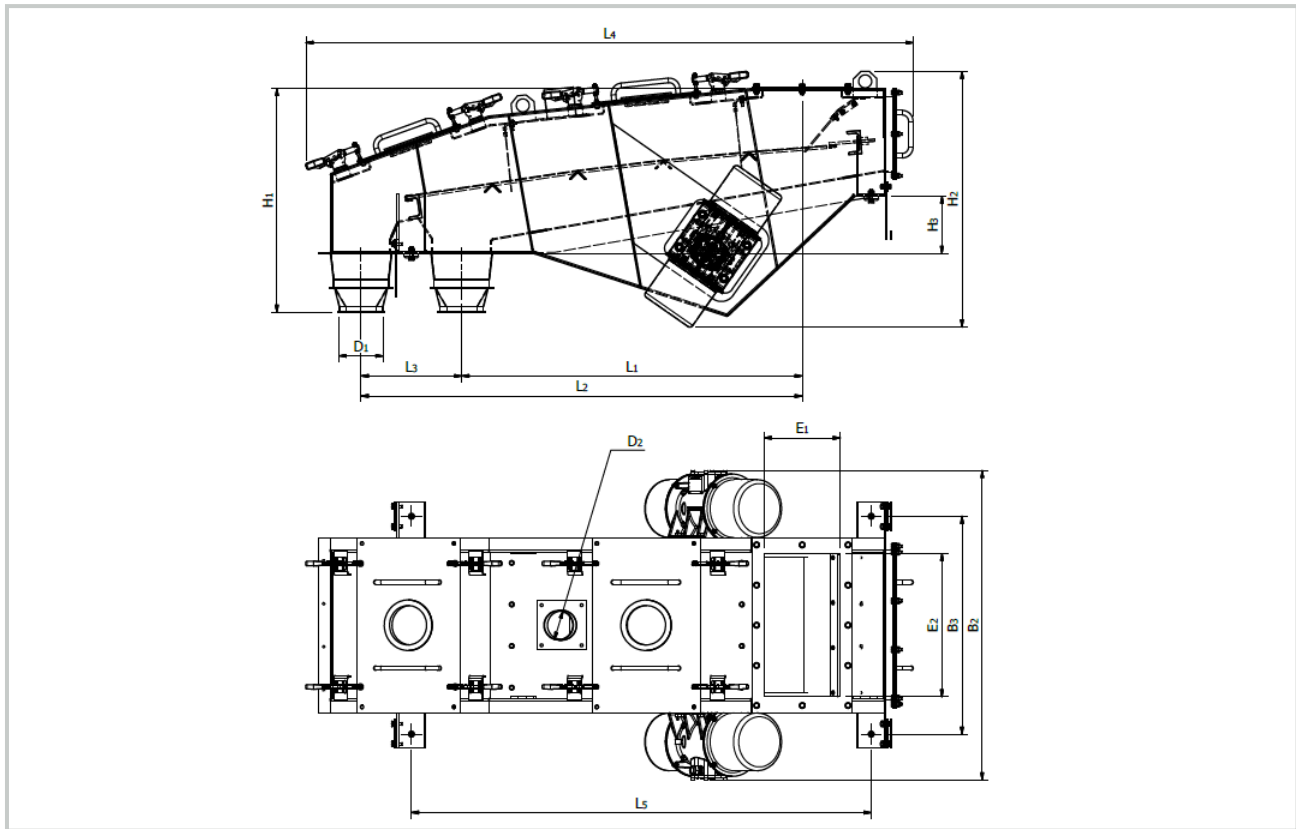

Type		RKS 500x1000	RKS 1000x2000
Vibrators	kW	2x 0,35	2x 0,75
Capacity (max)	m ³ /h	10	35
Screen inclination	°	5	7
D1	mm	150	200
D2	mm	100	100
E1	mm	265	265
E2	mm	500	800
L1	mm	620	1740
L2 (min / max)	mm	950	2220
L3	mm	335	480
L4	mm	1555	2830
L5	mm	1130	2200
B2	mm	985	1570
B3	mm	510	1010
H1	mm	630	830
H2	mm	620	930
H3	mm	0	213
Weight	kg	280	600

- Support frame not included
- Other sizes for lower / higher capacities on request