

## Horizontal Batch Blenders type RDM 2000 / 4000 / 6000 / 8000 / 12000

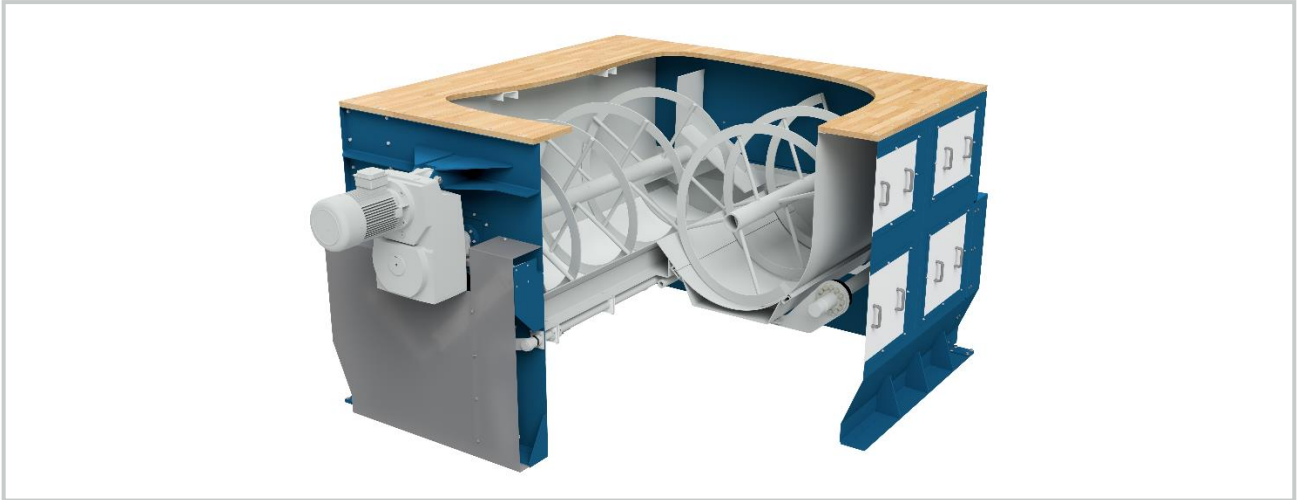

- Mixtures of all dry, grainy and free flowing products (grass seeds, cereals, pulses, etc.)
- No product damage and optimal homogeneity
- Solid steel construction for low wear and maintenance
- Easy cleaning and access to all parts
- Five sizes with 2.000 - 12.000 liter capacity

### Standard Construction

- Two shafts with counter-rotating spirals, each one driven by a drive motor
- End bearing assemblies with double shaft sealing
- Two-part, pneumatic bottom flap below the entire mixing chamber for fast and residue free discharge
- Frictional connection for flexible adjustment of discharge flap position
- Heavy-duty mixing chamber
- Completely closed, dust-proof housing for hygienic and clean operation
- Aspiration spouts

### Options

- Food safe execution (FDA) with stainless steel mixing chamber
- Support / Platform (static or mobile), optional with control pedestal
- Feed hopper, discharge hopper
- Conveyor equipment (belt conveyors, bucket elevators, continuous bucket conveyors, etc.) for feeding and discharging

| Type     |    | RDM 2000 | RDM 4000 | RDM 6000 | RDM 8000 | RDM 12000 |
|----------|----|----------|----------|----------|----------|-----------|
| Motors   | kW | 2x 4,0   | 2x 7,5   | 2x 11,0  | 2x 15,0  | 2x 22,0   |
| Capacity | l  | 2.000    | 4.000    | 6.000    | 8.000    | 12.000    |