

# Underrunner disc sheller type USG

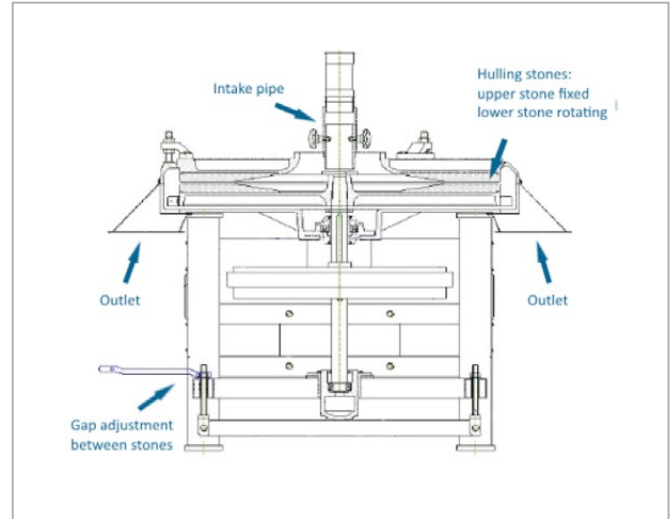

- Machine for hulling grain products and legumes (e.g. spelt wheat, soy beans, peas, lentils, lupines, buckwheat, millet)
- 2 hulling stones in robust hulling bed of cast iron
- Hand wheel on the machine frame for gap adjustment between both stones and also the hulling process intensity
- Continuous regulation of capacity by a variably adjustable intake pipe
- Quick discharge of the hulling mix and careful treatment of the hulled kernels by 2 opposite outlets
- Available in 2 sizes

## Technical data

Type	Capacity (t/h)	Motor (kW)	Dimensions (mm)	Weight (kg)	Air requirement (m <sup>3</sup> /min)
USG-750	0.85 – 1.5	5.5	1,151 x 1,183 x 1,480	420	max. 20
USG-1200	1.5 – 4.0	11.0	1,802 x 1,850 x 1,620	1,410	max. 20