

# Continuous bucket conveyors

## type WB-130 | 250 | 300 | 370 | 640 | 800

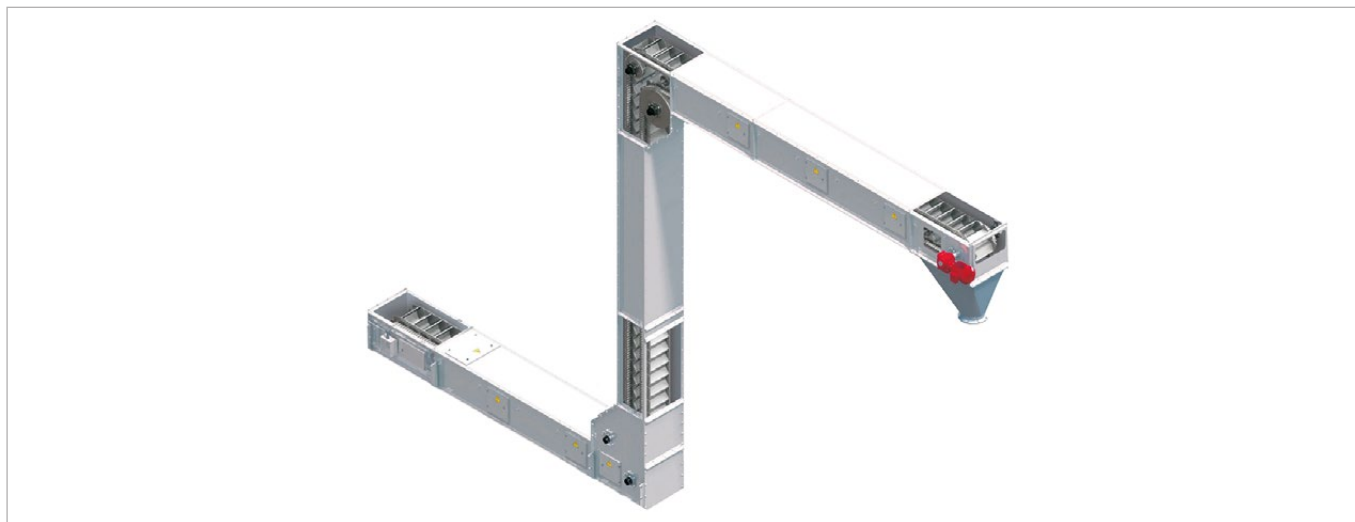

- Horizontal, vertical or inclining conveyance of bulk materials of any kind
- Mild treatment without disintegration of the conveyed material
- Homogeneous conveyance
- Low cleaning expenditure before product change
- According to requirements one or more feeding points possible
- Modular design adapted to individual demands
- High conveyance capacity at low drive power
- Conveying heights over 50 m possible, total conveying length is almost unlimited
- Housing in mild or stainless steel, in dust-, water-, gastight or shock pressure resistant execution
- Different configurations possible (C-, Z-, diagonal, etc.)

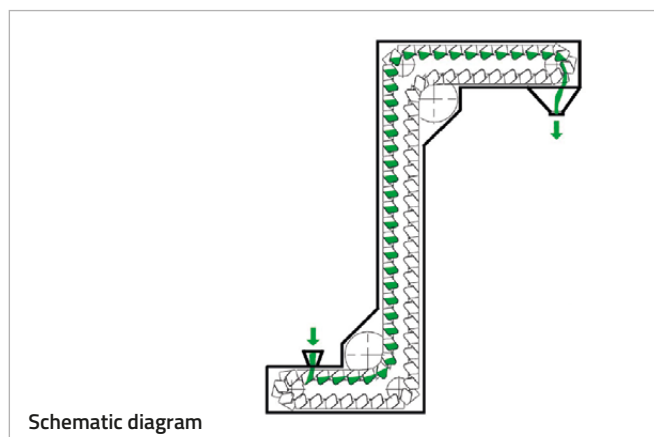

### Technical data

	WB-130	WB-250	WB-300	WB-370	WB-640	WB-800
Capacity in m <sup>3</sup> /h	4	12	22	45	90	150